

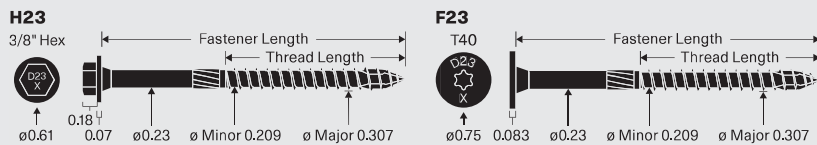

# Ledger to Stud with 0, 1, or 2 Layers of 5/8" Gypsum Structural H23 and F23

Starborn® Structural H23 and F23 Deck Ledger/Multipurpose Screws can be used to attach ledgers to wood studs with zero, one, or two layers of gypsum between the ledger and studs.



## INSTALLATION INSTRUCTIONS

- Select the proper length screw according to Table 2.
- Install screws while maintaining the required edge and end distances (Figures 2–5).
- Use a high-torque low-speed drill with a 3/8" hex or Torx® T40 driver bit. Pre-drilling is not required, but can be used where lumber is prone to splitting. For ledger end distances between 2" and 4", pre-drilling is recommended.
- Drive until the washer is drawn firm and flush. Do not overdrive or countersink.

## CORROSION RESISTANCE

- Structural H23 and F23 screws feature a high-adhesion exterior grade coating and are a code compliant alternative to hot-dip galvanized fasteners. The coating is approved for use in ACQ, Fire Retardant Treated (FRT), and other pressure treated lumbers.
- Structural H23 and F23 screws are not designed for use in or near saltwater environments.

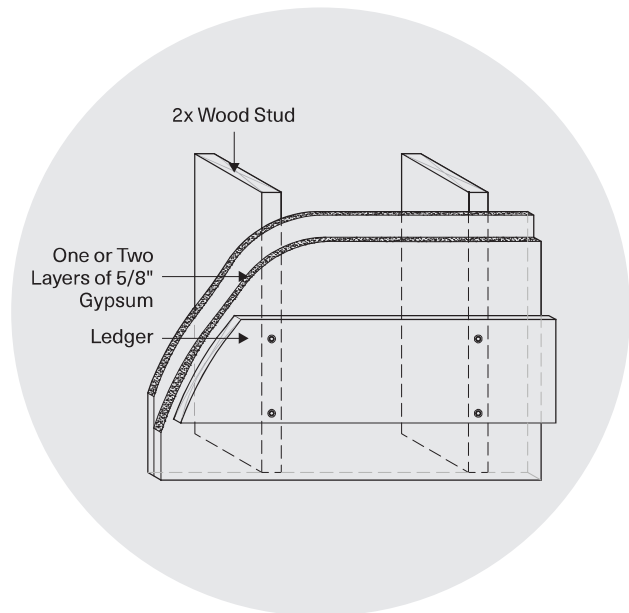

Figure 1

TABLE 1: Screw Properties

PRODUCT NAME	HEAD MARKING	UNTHREADED SHANK DIAMETER (IN)	HEAD TYPE	SCREW LENGTH (IN)	THREAD LENGTH (IN)
Structural H23	D23 4	0.23	Hex 3/8"	4	2-3/8
	D23 5			5	3
Structural F23	D23 4		Flat T40	4	2-3/8
	D23 5			5	3

For the most up to date version of this Technical Guide and more detailed information contained in the Deck Ledger and Ledger to Stud Applications code compliance report (DrJ TER 1703-01), visit [starbornindustries.com](http://starbornindustries.com). For applications outside the scope of this Technical Guide, an engineered design is required.

## Ledger to Stud with 0, 1, or 2 Layers of 5/8" Gypsum—Structural H23 and F23

**Figure 2—2x6 and 2x8 Ledger Configuration**

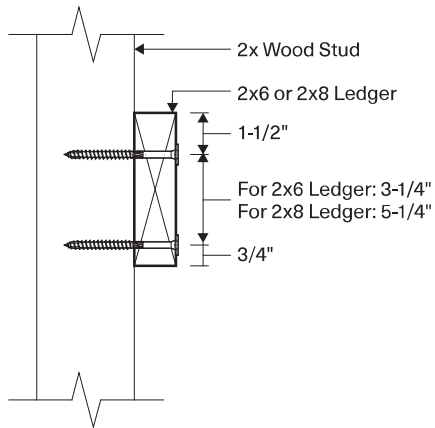

**Figure 3—2x10 Ledger Configuration**

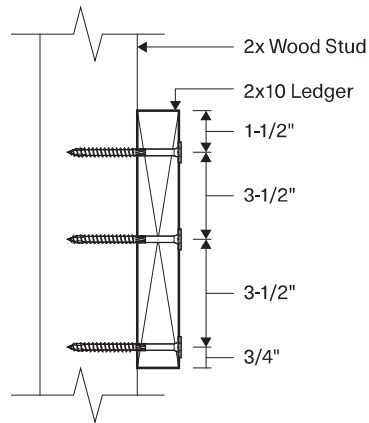

**Figure 4—2x6 and 2x8 Ledger Configuration with 1 or 2 Gypsum Interlayers**

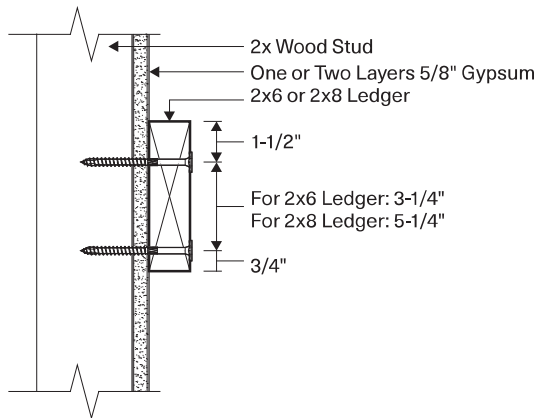

**Figure 5—2x10 Ledger Configuration with 1 or 2 Gypsum Interlayers**

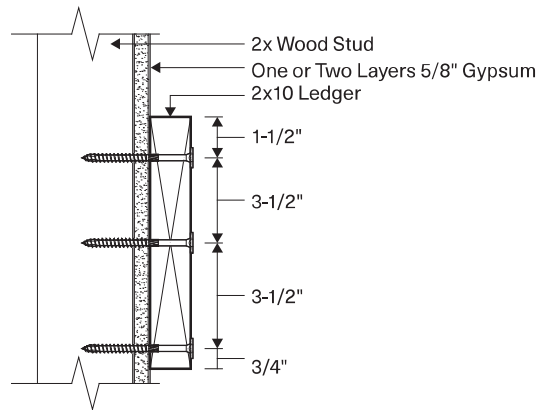

**TABLE 2: Reference Lateral Design Values for Ledger to Stud Connections With and Without Gypsum**

ALLOWABLE LOAD PER STUD CONNECTION (LBF) <sup>1</sup>						
SCREW LENGTH (IN)	MINIMUM PENETRATION INTO MAIN MEMBER (IN)	LAYERS OF 5/8" GYPSUM	NUMBER OF FASTENERS PER STUD	LEDGER SIZE		
				2x6	2x8	2x10
4	2-1/2	0	2	915	1190	
	1-7/8	1		815	1070	
5	2-1/4	2	3	845	1095	

1. The minimum ledger end distance is 6" for full values. For ledger end distances between 2" and 6" use 50% of the table loads. For end distances between 2" and 4", predrill using a 5/32" bit to prevent splitting.
2. Additional screws prohibited.
3. Ledger shall be Spruce-Pine-Fir (SPF) or any species with a specific gravity of 0.42 or greater.
4. Values apply to minimum 2x solid sawn lumber studs (parallel-to-grain loaded) and ledgers (perpendicular-to-grain loaded).
5. Allowable loads include a wood load duration (CD) = 1.0. Loads may be increased for load duration as permitted by the

6. building code up to CD = 1.6. All adjustment factors shall be applied per NDS. For in-service moisture content greater than 19%, use Wet Service Factor (CM) = 0.7.
6. Screws shall be centered in the stud and spaced as shown in Figures 2–5. Stud minimum end distance is 6-3/4" when loaded toward the end and 4" when loaded away from the end.
7. For Load Resistance Factor Design (LRFD) values, the reference connection design values shall be adjusted in accordance with NDS, Section 11.3.
8. Gypsum must be attached as required per the applicable building code.