

# Deck Ledger to Rim Joist

## Structural H23, F23, F23 Stainless

Starborn® Structural H23, F23, and F23 Stainless Deck Ledger/Multipurpose screws are specifically designed to attach deck ledgers to rim joists in accordance with IRC Section R507.9 and IBC Section 1604.8.3.

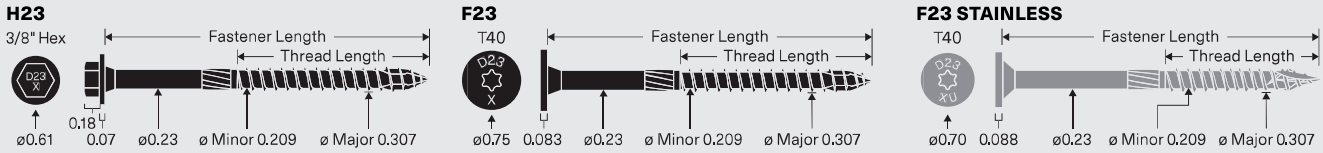

### INSTALLATION INSTRUCTIONS

- Select either the 4" or 5" screw so the threads fully engage the rim joist and the tip extends beyond its back face.
- Determine spacing pattern utilizing Table 2. Install screws in a staggered "W" pattern along the length of the ledger while maintaining the required edge and end distances (Figure 2).
- Use a high-torque low-speed drill with a 3/8" hex or Torx® T40 driver bit. Pre-drilling is not required, but can be used where lumber is prone to splitting.
- Drive until the washer is drawn firm and flush. Do not overdrive or countersink.

### CORROSION RESISTANCE

- Structural H23 and F23 screws feature a high-adhesion exterior grade coating and are a code compliant alternative to hot-dip galvanized fasteners. The coating is approved for use in ACQ, Fire Retardant Treated (FRT), and other pressure treated lumbers.
- Structural H23 and F23 screws are not designed for use in or near saltwater environments.
- Structural F23 Stainless screws are exterior grade and approved for use in ACQ and pressure treated lumber. For salt water or other areas where corrosion is a concern, use Grade 316 Stainless.
- All metal fasteners have the potential to corrode including stainless steel. For more information visit [starbornindustries.com/corrosion](http://starbornindustries.com/corrosion)

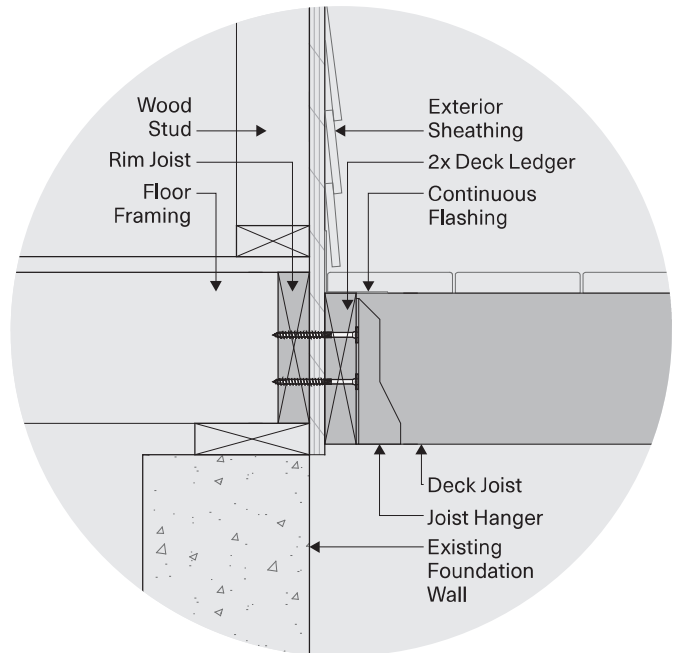

Figure 1—Deck Connection Assembly

TABLE 1: Screw Properties

PRODUCT NAME	HEAD MARKING	UNTHREADED SHANK DIAMETER (IN)	HEAD TYPE	SCREW LENGTH (IN)	THREAD LENGTH (IN)
Structural H23	D23 4	0.23	Hex 3/8"	4	2-3/8
	D23 5			5	3
Structural F23	D23 4		Flat T40	4	2-3/8
	D23 5			5	3
Structural F23 Stainless	D23 4		Flat T40	4	2-3/8
	D23 5			5	3

For the most up to date version of this Technical Guide and more detailed information contained in the Deck Ledger and Ledger to Stud Applications code compliance report (DrJ TER 1703-01), visit [starbornindustries.com](http://starbornindustries.com). For applications outside the scope of this Technical Guide, an engineered design is required.

**Deck Ledger to Rim Joist—Structural H23, F23, F23 Stainless**

**Figure 2—Minimum Spacing Requirements: Wood Rim Joist**

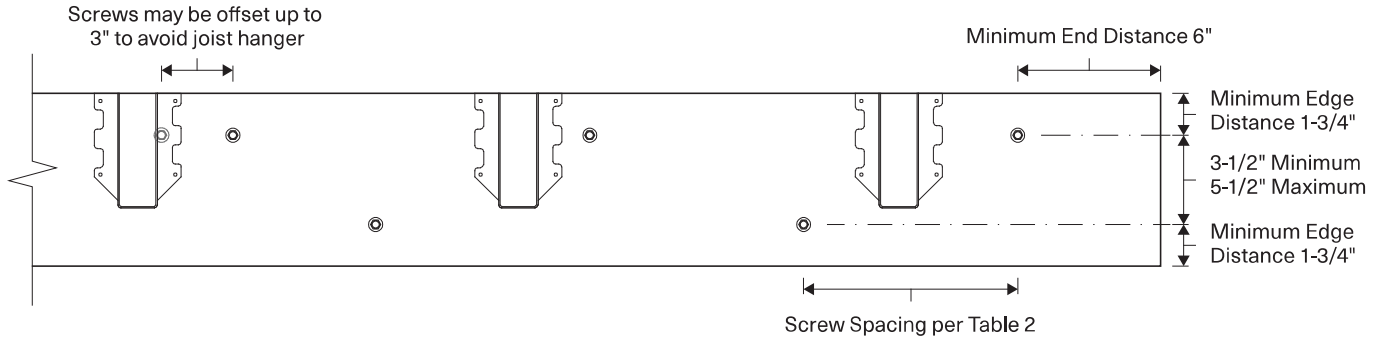

**TABLE 2: Structural H23 and F23 Screw Spacing for Items in IRC Table 507.9.1.3(1) & Other Materials & Loading Conditions**

LOADING CONDITION (PSF): LIVE LOAD + DEAD LOAD	SCREW LENGTH (IN)	RIM JOIST MATERIAL	2X LEDGER SPECIES	MAXIMUM DECK JOIST SPANS (FT)						
				UP TO 6	UP TO 8	UP TO 10	UP TO 12	UP TO 14	UP TO 16	UP TO 18
				MAXIMUM ON-CENTER FASTENER SPACING (IN)						
40+10	4	2x Sawn Lumber	HF/SPF	22	17	13	11	9	8	7
			DF/SP	30	22	18	15	12	11	10
		SCL	HF/SPF	24	18	14	12	10	9	8
			DF/SP	28	21	17	14	12	10	9
	5	2x Sawn Lumber	HF/SPF	24	18	14	12	10	9	8
			DF/SP	30	23	18	15	13	11	10
SCL		HF/SPF	26	19	15	13	11	9	8	
		DF/SP	30	23	18	15	13	11	10	
60+10	4	2x Sawn Lumber	HF/SPF	16	12	9	8	6	6	5
			DF/SP	21	16	12	10	9	8	7
		SCL	HF/SPF	17	13	10	8	7	6	5
			DF/SP	20	15	12	10	8	7	6
	5	2x Sawn Lumber	HF/SPF	17	13	10	8	7	6	5
			DF/SP	23	17	13	11	9	8	7
		SCL	HF/SPF	18	14	11	9	8	7	6
			DF/SP	22	16	13	11	9	8	7

1. Spacing for items in IRC 2018 Table 507.9.1.3(1) or IRC 2015 Table 507.2 and other materials and conditions.
2. 2x solid sawn lumber rim joists and ledger shall be HF/SPF (SG = 0.42) or DF/SP (SG = 0.50).
3. Minimum rim joist: 2x solid sawn lumber SPF (SG = 0.42) 1-1/2" thick and 7-1/4" deep; EWP (SG = 0.50) 1" thick and 7-1/4" deep.
4. Minimum ledger: 1-1/2" thick and 7-1/4" deep.
5. Ledger assumed to be in wet service condition.

6. Design values include a wood load duration ( $C_D$ ) = 1.0. Spacing may be adjusted by the applicable load duration as specified in NDS.
7. Screw spacing based on tested loads. The design values are the lesser of a 1/8" deflection or a safety factor greater than or equivalent to the code compliant lag screw application.
8. A maximum of 1/2" structural sheathing may be installed between the ledger and rim joist.

psf = pounds per square foot  
EWP = Engineered Wood Product

HF = Hem-Fir  
SPF = Spruce-Pine-Fir

DF = Douglas Fir  
SP = Southern Pine

SG = Specific Gravity

**TABLE 3:** Structural F23 Stainless Screw Spacing for Items in IRC Table 507.9.1.3(1) & Other Materials & Loading Conditions

LOADING CONDITION (PSF): LIVE LOAD + DEAD LOAD	SCREW LENGTH (IN)	RIM JOIST MATERIAL	2X LEDGER SPECIES	MAXIMUM DECK JOIST SPANS (FT)						
				UP TO 6	UP TO 8	UP TO 10	UP TO 12	UP TO 14	UP TO 16	UP TO 18
				MAXIMUM ON-CENTER FASTENER SPACING (IN)						
40+10	4	2x Sawn Lumber	HF/SPF	20	15	12	10	8	7	6
			DF/SP	21	15	12	10	9	7	7
		SCL	HF/SPF	20	15	12	10	8	7	6
			DF/SP	23	17	13	11	9	8	7
	5	2x Sawn Lumber	HF/SPF	20	15	12	10	8	7	6
			DF/SP	21	15	12	10	9	7	7
		SCL	HF/SPF	20	15	12	10	8	7	6
			DF/SP	23	17	13	11	9	8	7
60+10	4	2x Sawn Lumber	HF/SPF	14	11	8	7	6	5	4
			DF/SP	15	11	9	7	6	5	5
		SCL	HF/SPF	14	10	8	7	6	5	4
			DF/SP	16	12	9	8	7	6	5
	5	2x Sawn Lumber	HF/SPF	14	11	8	7	6	5	4
			DF/SP	15	11	9	7	6	5	5
		SCL	HF/SPF	14	10	8	7	6	5	4
			DF/SP	16	12	9	8	7	6	5

1. Spacing for items in IRC 2018 Table 507.9.1.3(1) or IRC 2015 Table 507.2 and other materials and conditions.
2. 2x solid sawn lumber rim joists and ledger shall be HF/SPF (SG = 0.42) or DF/SP (SG = 0.50).
3. Minimum rim joist: 2x solid sawn lumber SPF (SG = 0.42) 1-1/2" thick and 7-1/4" deep; EWP (SG = 0.50) 1" thick and 7-1/4" deep.
4. Minimum ledger: 1-1/2" thick and 7-1/4" deep.
5. Ledger assumed to be in wet service condition.

6. Design values include a wood load duration ( $C_D$ ) = 1.0. Spacing may be adjusted by the applicable load duration as specified in NDS.
7. Screw spacing based on tested loads. The design values are the lesser of a 1/8" deflection or a safety factor greater than or equivalent to the code compliant lag screw application.
8. A maximum of 1/2" structural sheathing may be installed between the ledger and rim joist.

psf = pounds per square foot  
EWP = Engineered Wood Product

HF = Hem-Fir  
SPF = Spruce-Pine-Fir

DF = Douglas Fir  
SP = Southern Pine

SG = Specific Gravity