



# **SIMPLICLAD™**

## Open-Joint Cladding Installation Guide

Rainscreens are a form of siding construction also referred to here as cladding. In a rainscreen installation the cladding is spaced off of the building wall using furring for increased ventilation and drainage. The additional ventilation and drainage provides many benefits such as allowing the building to breathe, reducing moisture build-up and minimizing the formation of mold. Open-joint rainscreens have gaps between the cladding boards to provide more ventilation and aesthetic appeal than closed-joint rainscreens.

# System Components

## OPEN-JOINT RAINSCREEN CONSTRUCTION USING METAL FURRING

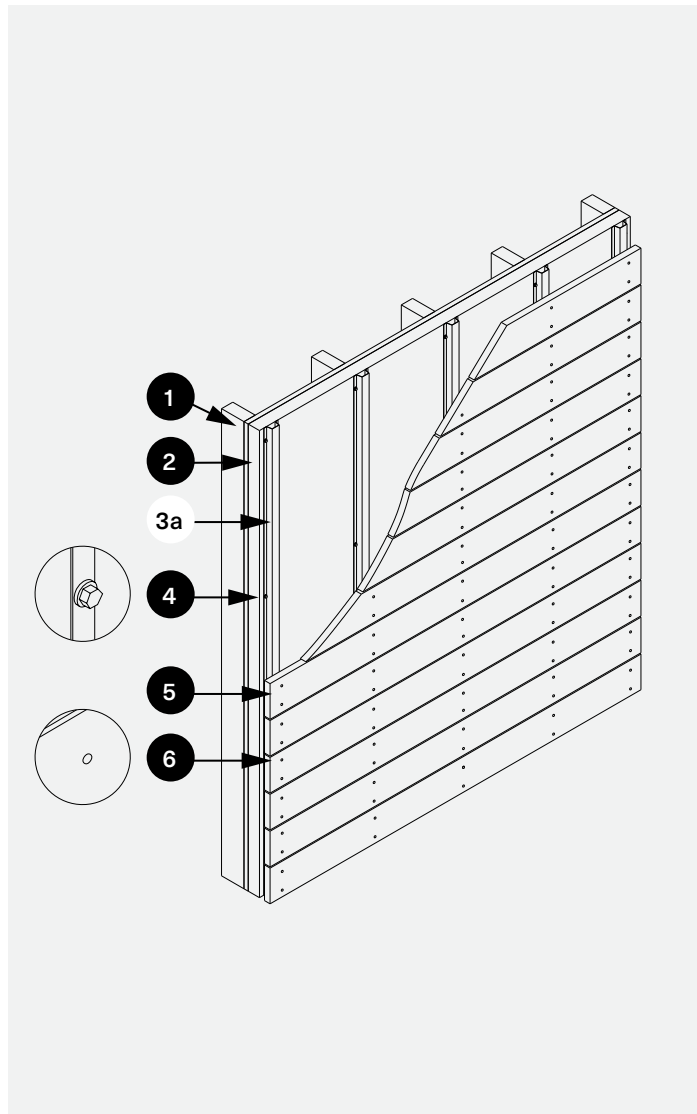

## ALTERNATE FURRING TYPES

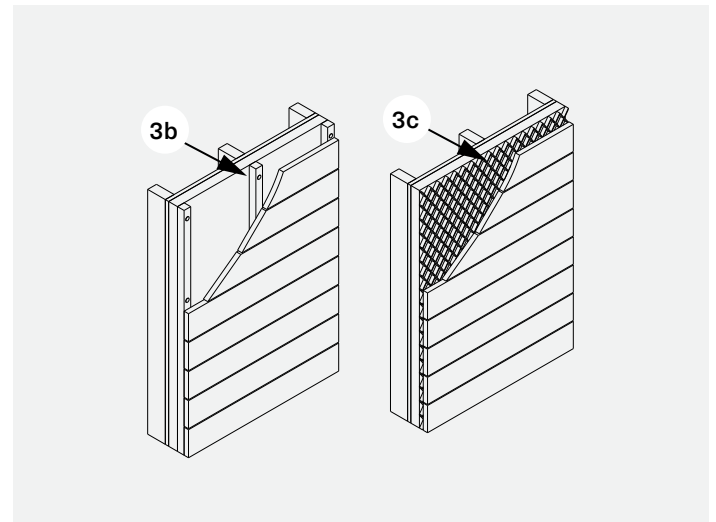

### FURRING STRIP PROFILES (not to scale)

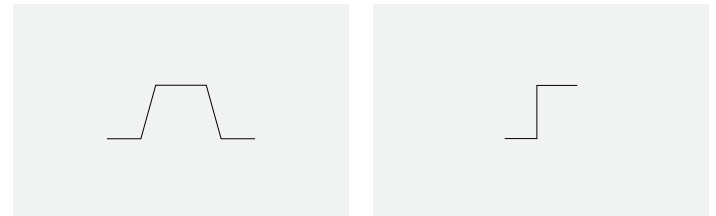

Hat Channel

Z Channel

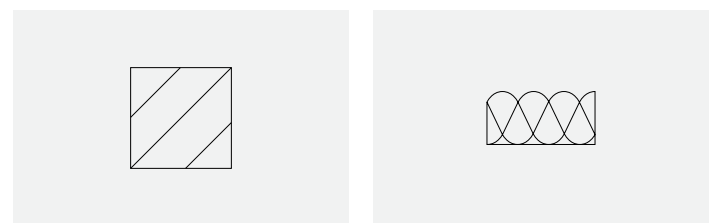

Wood Furring

Building Wrap/Mesh

- (1) **Wall Construction:** Can be wood or metal studs covered by sheathing and a weather or water resistant barrier (WRB) or concrete masonry units (CMU).
- (2) **Exterior Wall Insulation:** Rigid foam panels used on building exteriors for additional insulation is needed.
- (3) **Furring:** Spaces the cladding boards off the building envelope. Furring strips can be:
  - (a) Metal Hat or Z Channel (16–20 gauge)
  - (b) Wood Furring (Pressure Treated Lumber)
  - (c) Building Wrap/Mesh specific for rainscreen construction
  - (d) Composite
- (4) **Structural Screws:** Code compliant fasteners for tying structural furring strips back to building structure.

- (5) **Cladding Boards:** Can consist of composite, PVC, hardwood, or thermally modified wood boards.
- (6) **Cladding Screws:** Fasten the cladding board to the furring strip or through the furring strip back to the wall assembly. Screws can be color matched surface fasteners or hidden with Starborn® Pro Plug® System.

All components listed above can be used in tandem with SimpliClad™ Rainscreen System App; an interactive web tool by Starborn® which provides the best fastening solutions for rainscreen construction based on inputs such as board selection, furring strip selection, insulation thickness, and wall construction.

### USING THE SIMPLICLAD™ APP

1. On the home page, select **Choose My Board** to see all available boards that are approved for rainscreen construction with Starborn® SimpliClad™ System. Boards are separated by material with all available brands and associated thicknesses listed.
2. Continue to the **Plan My Job** section of the app and fill out selections in accordance with the project such as the environment, board type and orientation, desired fastening, wall construction, sheathing thickness, exterior insulation thickness and furring type.
3. Input project information including the square footage of cladding, stud spacing, and board weight.
4. Click **Generate Report** to get a bill of materials report that lists the proper fastener recommendations as well as material quantity estimates for the job.

### USING THE SIMPLICLAD™ MATRICES

The SimpliClad™ Matrices are a series of tables on the SimpliClad™ webpage which can be manually consulted in lieu of using the SimpliClad™ App. Use the matrices to find the recommended fasteners for the job, then proceed to the SimpliClad™ SKU Lookup to find specific part numbers.

### USING THE SIMPLICLAD™ SKU LOOKUP

The SimpliClad™ SKU Lookup makes it easy to locate the proper hardware for any project, complementing the efficiency of the SimpliClad™ App and SimpliClad™ Design Matrices. Whether sourcing materials based on the app's recommendations or manually selecting components, the SKU Lookup ensures quick access to the product SKUs.

### INSTALLATION

Follow all board manufacturer installation instructions for screw spacing, edge/end distances, and gapping. All rainscreen elements including furring strips and sheathing must be securely fastened to the building structure in accordance with building code before the cladding board can be attached. Consulting with a professional engineer or architect is always best practice to determine the best fastening patterns.

### FASTENING THE FURRING TO STUD

Starborn® Structural screws for mounting furring strips over exterior insulation come in both epoxy coated carbon steel and 316 stainless steel. All Starborn® Structural fastener values and spacing recommendations for cladding application can be found in the DrJ TER 1703-04: Cladding Attachment Through Foam Sheathing code compliance report.

- **Structural F19**—Epoxy coated flat head, 0.19" shank structural screw.

- **Structural H19**—Epoxy coated hex head, 0.19" shank structural screw.
- **Structural F23**—Epoxy coated flat head, 0.23" shank structural screw.
- **Structural F23 Stainless**—316 stainless, flat head, 0.23" shank structural screw. Available uncoated or with black head coat.
- **Structural SDP18 Self Drill**—Epoxy coated pan head, 0.18" shank structural screw with self drill point for 16–20 gauge steel studs. New product, anticipated availability March 2025.

1. Determine if the furring being used is structural or non-structural:
  - (a) Structural furring strips such as two-by pressure treated lumber or metal hat or Z channels structurally support the cladding board. The cladding board is fastened directly to the furring strip and the furring strips are tied back to the building envelope using code compliant structural fasteners. For buildings where the wall construction consists of metal studs or concrete masonry units (CMU), structural furring is recommended.
  - (b) Non-structural furring strips such as wood furring less than 1-1/2" thick or building wrap/mesh serve only as spacers and do not support the weight of the cladding board. Structural fasteners are not required here, however the fastener responsible for tying the board down must get at least 1" of penetration into the building stud to sufficiently support the cladding board.

Consult the SimpliClad™ Rainscreen System web application to find the best fastening solution for each furring strip option.

2. Calculate screw spacing using Table 3 through 8 on the DrJ TER 1703-04: Cladding Attachment Through Foam Sheathing code compliance report:
  - (1) Determine stud material and spacing.
  - (2) Choose foam thickness to obtain required insulation effect/R-value.
  - (3) Select furring. For marine applications wood furring must be used.
  - (4) Determine cladding weight per manufacturer's specifications.
3. Select the proper length screw. For wood studs, a minimum of 1" penetration is required, however the screw should not penetrate through the backside of the stud. For metal studs, a minimum of 3 screw threads behind the metal stud is required. For marine applications, wood furring with a F23 316 stainless steel structural screw must be used.
4. Install the screw using a high-torque, low-speed drill with the proper bit. For wood furring predrilling is only required when fastening into steel studs or CMU block wall, but can also be used where lumber is prone to splitting. For metal furring, predrilling with a 5/16" drill bit made from HSS, cobalt or with a black oxide or titanium finish is recommended. Using an impact driver is not recommended when fastening into steel studs.
5. Drive the screw until the washer on the screw head is firm and flush with no gaps between the layers of materials. Do not overdrive or countersink.

## FASTENING THE CLADDING BOARD

Follow all cladding board manufacturer's installation instructions for screw spacing, edge/end distances, and gapping. For non-branded products or instances where there are no manufacturer's instructions, leave a minimum of 3/16" gap between boards.

Starborn® screws for the cladding board are available in epoxy coated, grade 305 or grade 316 stainless, or epoxy coated 410 stainless for metal framing.

- **Cap-Tor® xd**—for fastening composite or PVC cladding boards to wood furring or stud. Available in epoxy coated carbon steel, 305 stainless steel, or 316 stainless steel.
  - **Cap-Tor® Metal**—for fastening composite, PVC, or hardwood cladding boards to metal furring. Available in 1-1/2" for 20 and 18 gauge steel furring or 1-5/8" for 16 gauge steel furring.
  - **Headcote®** —for fastening hardwood deck boards to wood furring or stud. Available in 305 stainless steel or 316 stainless steel.
  - **Pro Plug® System Composite/PVC**—hidden fastening system for composite or PVC cladding boards. Available in epoxy coated carbon steel, 305 stainless steel, or 316 stainless steel. Also available in 410 stainless steel for fastening to metal furring.
  - **Pro Plug® System Wood**—hidden fastening system for hardwood boards. Available in 305 stainless steel, or 316 stainless steel. Also available in 410 stainless steel for fastening to metal furring.
1. Select the appropriate fastener for the cladding board and furring strip being used.
    - (a) If the furring strip chosen is non-structural and cannot support the cladding board on its own, the cladding board fastener must penetrate wood studs a minimum of 1".
    - (b) If the furring strip chosen is structural, fasteners must have a minimum of 1" of penetration into wood furring or a minimum of 3 screw threads behind a metal furring.

Consult the SimpliClad™ Rainscreen System web application to find the best fastening solution for each furring strip option.

2. Ensure the board is level and install 2 fasteners at each furring strip in a straight and steady fashion. If a building wrap/mesh is used for furring, install 2 fasteners in cladding board at each stud.

## FOR VERTICAL BOARD INSTALLATION

1. When cladding boards are vertical, 1-1/2" thick wood furring must be used, where two layers of the 1-1/2" thick wood furring must be installed in a crosshatched pattern.
2. Install the first layer of furring vertically in line with the building studs at a maximum of 24" on center using the proper Starborn® Structural fastener.
3. Install the second layer of furring horizontally so that it is perpendicular to the first layer of furring. Use Starborn® Structural F19, F23 or F23 Stainless 2-7/8" screws to fasten the second layer of furring to the first layer.

4. Select the appropriate fastener for the cladding board and install 2 fasteners at each furring strip in a straight and steady fashion.

## FOR DIAGONAL BOARD INSTALLATION

- Refer to deck board manufacturer's instructions for all furring spacing and fastening requirements. Note: not all manufacturers recommend their boards for diagonal
- For non-branded products we are not able to recommend this orientation at this time as it is subject to product specific testing.

## IMPORTANT INFORMATION

- Before mounting any cladding elements, prepare the wall by installing the proper WRB and flashing at all corners and penetrations in the wall including all doors and windows.
- Wherever a butt end of two boards occurs, install a minimum 1x4 wood furring strip or 3-inch wide hat channel.
- When hat channel is installed and no exterior insulation is present, a Starborn® Hex Self Drill 410 stainless steel screw may be used in tandem with Starborn structural screws to pin down the hat channel to the sheathing.
- To prevent thermal bridging, it is best practice to cover and seal structural screw heads with foam where possible.
- Map out mechanical systems before installing furring strips.
- To prevent spin out, when building wrap/mesh is used for furring, pre-drill the deck board with a 7/32" jobber bit and install 2 fasteners in cladding board at each stud.

## WARRANTY

Starborn® warrants its products to be free from defects in material and manufacturing. Starborn's liability is limited to the purchase price of the product.

## CORROSION INFORMATION

For salt water and other corrosive environments 316 stainless is recommended. All metal fasteners have the potential to corrode. Follow all board manufacturer instructions. For more information, visit [starbornindustries.com/ci](http://starbornindustries.com/ci).

Starborn® Structural H19, F19, F23, and P18 screws feature a high-adhesion exterior grade coating and are a code compliant alternative to hot-dip galvanized fasteners. The coating is approved for use in ACQ, Fire Retardant (FRT), and other pressure treated lumbers. Structural H19, F19, F23 and P18 screws are not designed for use in or near saltwater environments. Starborn® Structural F23 Stainless has a 316 stainless finish which is recommended for salt water and all other corrosive environments.