

Multi-Ply Dimensional Wood Connections

Structural F23-W, F23, and F19

Starborn® Structural F23-W Multi-Ply Dimensional Wood screws are designed for single-sided joining of multi-ply 2x wood beams in interior applications. For exterior applications use F19 or F23 Multipurpose screws with IRC Section R507.9 and IBC Section 1604.8.3.

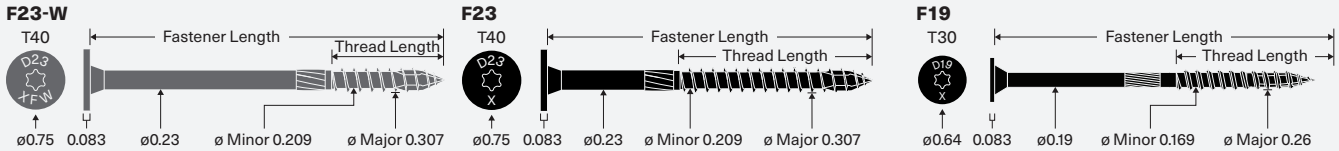

INSTALLATION INSTRUCTIONS

- Select the proper length screw according to Table 2, ensuring a minimum 1" penetration into the main member (final member in the multi-ply assembly).
- Install using a high-torque low-speed drill with a Torx® T30 or T40 driver bit. Pre-drilling is not required, but can be used where lumber is prone to splitting.
- Drive until the washer is drawn firm and flush. Do not overdrive or countersink.
- **Caution:** Do not connect warped or curved wood members. Forcing alignment with clamps, screws or bolts may decrease the carrying load of the beam or split the wood.

FINISH AND COATING

- Structural F23-W screws have a gray e-coat finish and are designed for interior use only.
- Structural F19 and F23 screws have a black, high-adhesion exterior grade coating and are a code compliant alternative to hot-dip galvanized fasteners. This coating is approved for use in ACQ, Fire Retardant Treated (FRT), and other pressure treated lumbers.
- Structural F19, F23, and F23-W screws are not designed for use in or near saltwater environments.

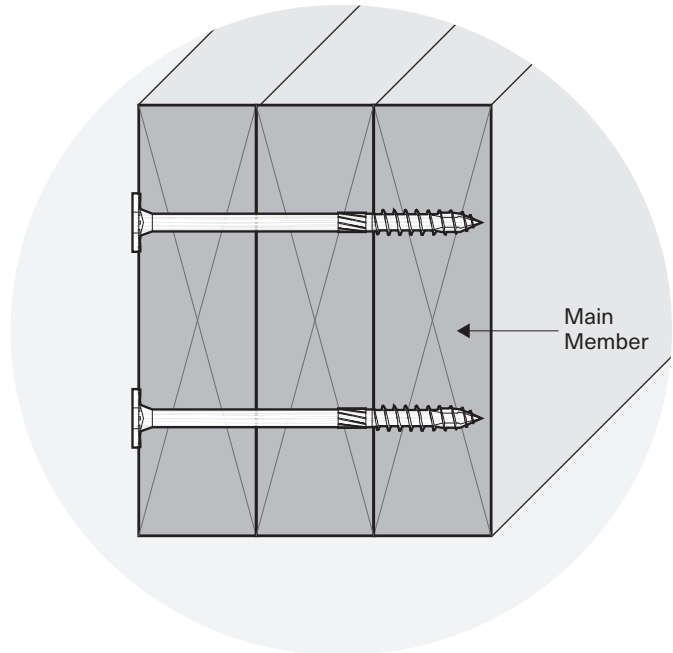

Figure 1

TABLE 1: Screw Properties

PRODUCT NAME	HEAD MARKING	UNTHREADED SHANK DIAMETER (IN)	HEAD TYPE	SCREW LENGTH (IN)	THREAD LENGTH (IN)
Structural F19 (exterior)	D19 2.9	0.19	Flat T30	2-7/8	2
	D19 4.5			4-1/2	
	D19 6			6	
Structural F23-W (interior)	D23 2.9 XFW	0.23	Flat T40	2-7/8	1.4
	D23 4.4 XFW			4-3/8	
	D23 5.9 XFW			5-7/8	
Structural F23 (exterior)	D23 2.9	0.23	Flat T40	2-7/8	1.4
	D23 4			4	2-3/8
	D23 5			5	3
	D23 6			6	2-3/4

For the most up to date version of this Technical Guide and more detailed information contained in the Multi-Ply Applications code compliance report (DrJ TER 1703-03), visit starbornindustries.com. For applications outside the scope of this Technical Guide, an engineered design is required.

Multi-Ply Dimensional Wood Connections—Structural F23-W, F23, and F19

Figure 2—Minimum Spacing Requirements

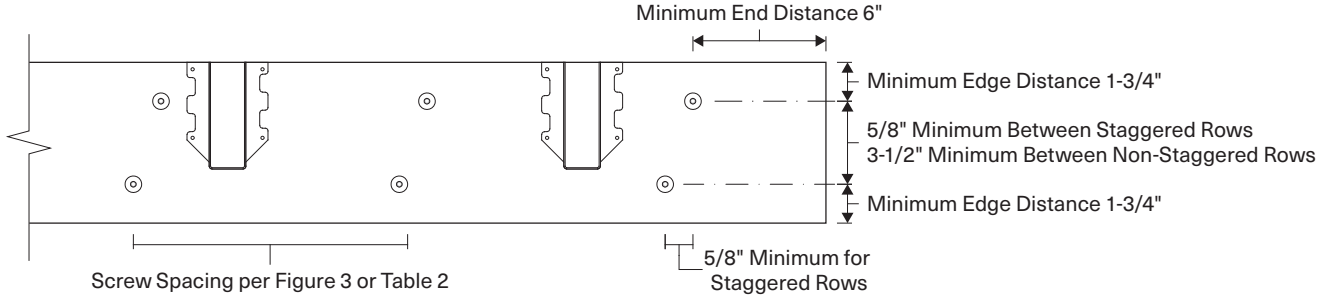

Figure 3—Top Loaded Beams

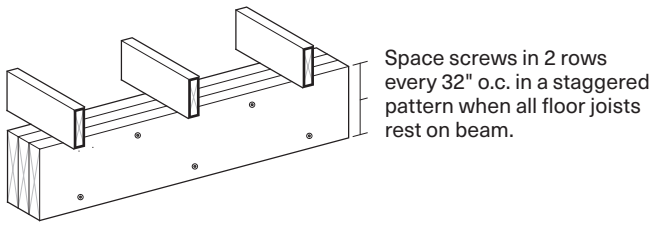

Figure 4—Dimensional Wood Assemblies

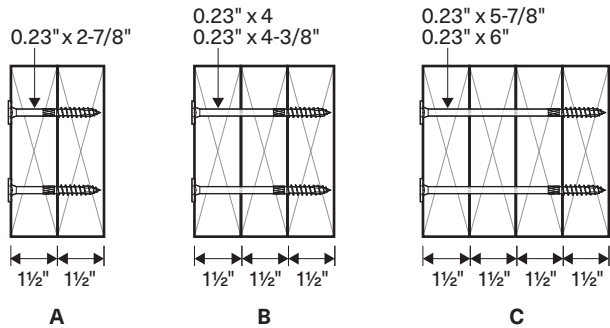

TABLE 2: Allowable Side Load Capacity (plf)

WOOD SPECIES (SPECIFIC GRAVITY)			HF/SPF (0.42)						DF/SP (0.50)					
ASSEMBLY	COMPONENTS	PRODUCT: SCREW LENGTH (IN)	12" O.C.		16" O.C.		24" O.C.		12" O.C.		16" O.C.		24" O.C.	
			2 ROWS	3 ROWS	2 ROWS	3 ROWS	2 ROWS	3 ROWS	2 ROWS	3 ROWS	2 ROWS	3 ROWS	2 ROWS	3 ROWS
A	2-ply 1-1/2"	F19: 2-7/8	1160	1740	870	1305	580	870	1520	2280	1145	1720	760	1140
		F23-W: 2-7/8	1460	2190	1100	1650	730	1095	1660	2490	1250	1875	830	1245
		F23: 2-7/8												
B	3-ply 1-1/2"	F19: 4-1/2	1140	1710	855	1285	570	855	870	1305	655	985	435	655
		F23-W: 4-3/8	1260	1890	945	1420	630	945	1680	2520	1265	1900	840	1260
		F23: 4												
C	4-ply 1-1/2"	F19: 6	870	1305	655	985	435	655	1140	1710	855	1285	570	855
		F23-W: 5-7/8	1120	1680	840	1260	560	840	1495	2245	1125	1690	750	1125
		F23: 6												

1. May be loaded from either the head or point side.
2. Design values include a duration load (C_D) = 1.0. Values may be multiplied by all applicable adjustment factors per NDS.

plf = pounds per linear foot
 SP = Southern Pine

HF = Hem-Fir
 o.c. = on-center

SPF = Spruce-Pine-Fir
 DF = Douglas Fir