

# Cold Formed Steel (CFS) Ledger to Rim Joist Structural H23 and F23

Starborn® Structural H23 and F23 Deck Ledger/Multipurpose screws are specifically designed to attach deck ledgers to rim joists in accordance with IRC Section R507.9 and IBC Section 1604.8.3.

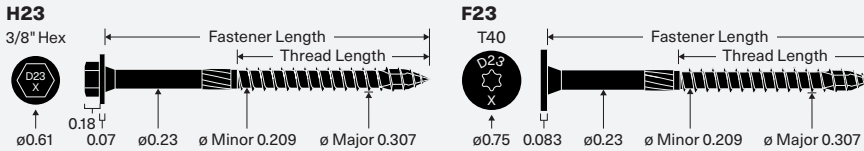

## INSTALLATION INSTRUCTIONS

- Minimum fastener length to be used is 2-7/8". Fasteners are required to have full thread penetration into the main member.
- Determine spacing pattern utilizing Table 2. Install screws in a staggered "W" pattern along the length of the ledger while maintaining the required edge and end distances (Figure 2).
- Using a step bit predrill holes in steel ledger.
- Use a high-torque low-speed drill with a 3/8" hex or Torx® T40 driver bit. Pre-drilling is not required, but can be used where lumber is prone to splitting.
- Drive until washer is drawn firm to steel ledger and there are not air gaps between the steel ledger and wood sheathing or rim plate.

## CORROSION RESISTANCE

- Structural H23 and F23 screws feature a high-adhesion exterior grade coating and are a code compliant alternative to hot-dip galvanized fasteners. The coating is approved for use in ACQ, Fire Retardant Treated (FRT), and other pressure treated lumbers.
- Structural H23 and F23 screws are not designed for use in or near saltwater environments.

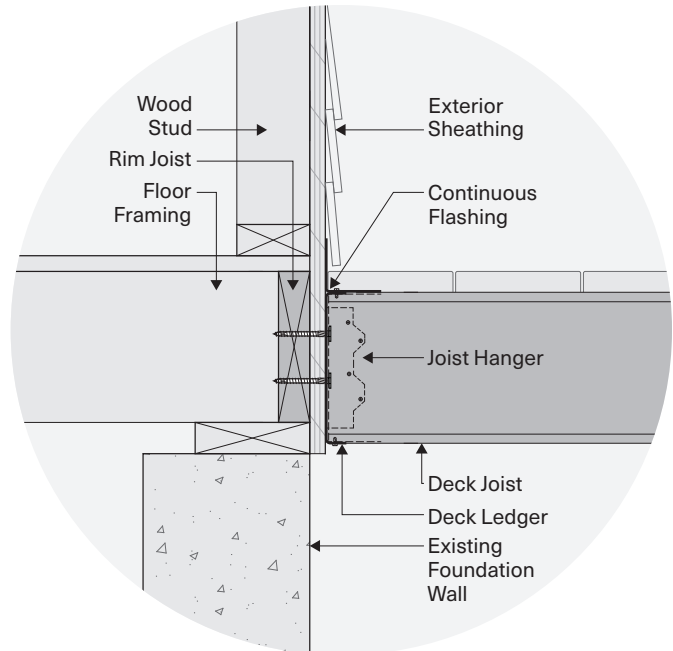

Figure 1—Deck Connection Assembly

TABLE 1: Screw Properties

PRODUCT NAME	HEAD MARKING	UNTHREADED SHANK DIAMETER (IN)	HEAD TYPE	SCREW LENGTH (IN)	THREAD LENGTH (IN)
Structural H23	D23 4	0.23	Hex 3/8"	4	2-3/8
	D23 5			5	3
Structural F23	D23 2.9		Flat T40	2-7/8	1-2/5
	D23 4			4	2-3/8
	D23 5			5	3

For the most up to date version of this Technical Guide and more detailed information contained in the Deck Ledger and Ledger to Stud Applications code compliance report (DrJ TER 1703-01), visit [starbornindustries.com](http://starbornindustries.com). For applications outside the scope of this Technical Guide, an engineered design is required.

**Deck Ledger to Rim Joist—Structural H23 and F23**

**Figure 2—Minimum Spacing Requirements: Cold Formed Steel (CFS)**

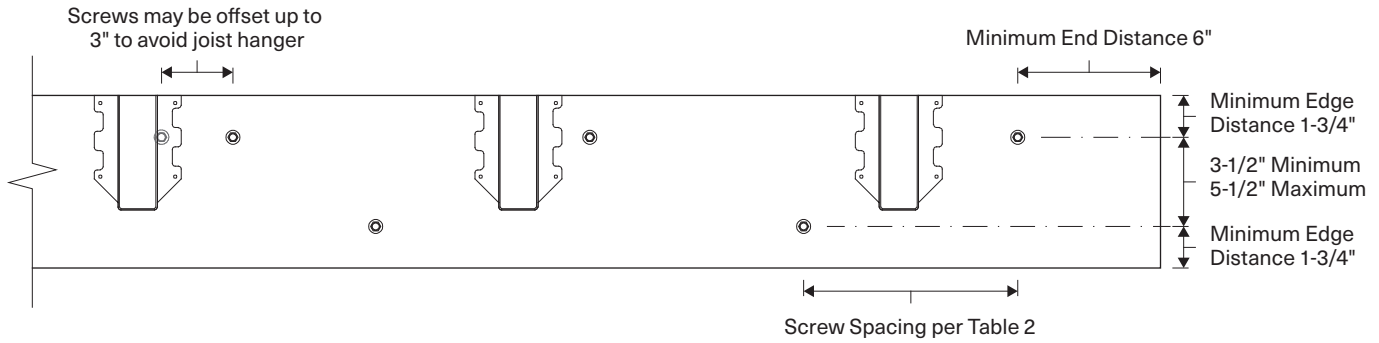

**TABLE 2: IRC Compliant Screw Spacing Pattern for Attaching a Cold Formed Steel (CFS) Deck Ledger to a Rim Joist**

LOADING CONDITION (PSF); LIVE LOAD + DEAD LOAD	LEDGER <sup>6</sup>		RIM JOIST MATERIAL	MAXIMUM DECK JOIST SPANS (FT)						
				UP TO 6	UP TO 8	UP TO 10	UP TO 12	UP TO 14	UP TO 16	UP TO 18
				MAXIMUM ON-CENTER FASTENER SPACING (IN)						
40+10	F <sub>y</sub> = 33ksi	12 gauge	HF/SPF	10	8	6	5	4	4	3
			DF/SP/SCL	14	11	8	7	6	5	4
		14 gauge	HF/SPF	10	8	6	5	4	4	3
			DF/SP/SCL	14	10	8	7	6	5	4
	F <sub>y</sub> = 50ksi	16 gauge	HF/SPF	10	7	6	5	4	3	3
			DF/SP/SCL	14	10	8	7	6	5	4
		12 gauge	HF/SPF	11	8	6	5	4	4	3
			DF/SP/SCL	15	11	9	7	6	5	5
60+10	F <sub>y</sub> = 33ksi	14 gauge	HF/SPF	10	8	6	5	4	4	3
			DF/SP/SCL	14	11	8	7	6	5	4
		16 gauge	HF/SPF	10	8	6	5	4	4	3
			DF/SP/SCL	14	11	8	7	6	5	4
	F <sub>y</sub> = 50ksi	12 gauge	HF/SPF	8	6	5	4	3	3	2
			DF/SP/SCL	12	9	7	6	5	4	4
		14 gauge	HF/SPF	8	6	5	4	3	3	2
			DF/SP/SCL	11	8	7	5	5	4	3
		16 gauge	HF/SPF	8	6	5	4	3	3	2
			DF/SP/SCL	11	8	7	5	5	4	3

- Based on load duration, Cd, of 1.00 for live load conditions, and 1.15 for snow load conditions. Spacing may be adjusted by the applicable load duration for other conditions as specified in the NDS.
- Fasteners are required to have full thread penetration into the main member. Minimum fastener length to be used is 2-7/8".
- Solid sawn band joists shall be HF/SPF or SP/DF species (Specific gravity of 0.42 and 0.50 respectively). Sawn lumber band joist 1.5" thick and 7.25" depth; SCL band joist 1.0" thick and 7.25 depth.
- Similar to the wood-ledger application, fasteners shall be staggered from the top to the bottom along the length of the ledger while maintaining the required edge and end distances.
- A maximum 1/2" structural sheathing may be installed between the ledger and the band joist.
- Minimum CFS ledger board requirements: 1.5" flange thickness and 8" depth.

psf = pounds per square foot  
EWP = Engineered Wood Product

HF = Hem-Fir  
SPF = Spruce-Pine-Fir

DF = Douglas Fir  
SP = Southern Pine

SG = Specific Gravity