

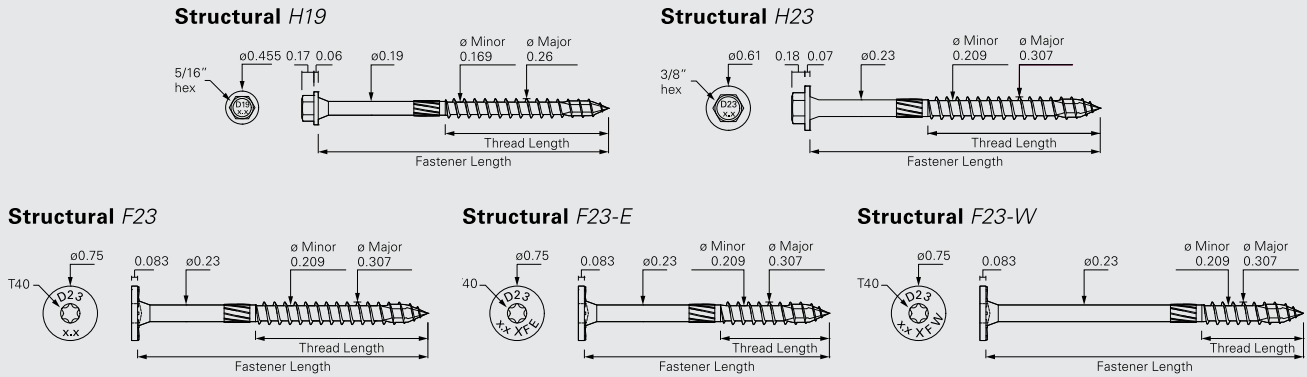

# Structural Screws

## Screw Properties and Design Values

For more detailed information, refer to the Code Compliance Report: Fastener Properties and Design Values (DrJ TER 1703-05) available at [starbornindustries.com](http://starbornindustries.com).



**Table 1: Reference Lateral Design Values for Single Shear Connections**

Product Name	Head Marking	Unthreaded Shank Diameter (in)	Head Type	Screw Length (in)	Thread Length (in)	Side Member Thickness (in)	Main Member Penetration (in)	Lateral Design Values (lbf) by Species (SG) and Load Orientation			
								HF/SPF (0.42)		DF/SP/SCL (0.50)	
								Z Perp	Z Para	Z Perp	Z Para
Structural H19	D19 2.9	0.19	Hex	2-7/8	1.4	1-1/2	1-3/8	230	230	225	245
	D19 4			4	2-1/4		2-1/2	305	230	300	345
	D19 6			6	2-1/2		4-1/2				
	D19 8			8			6-1/2				
	D19 10			10	8-1/2						
Structural H23	D23 4	0.23	Hex	4	2-3/8	1-1/2	2-1/2	405	280	540	485
	D23 5			5	3		3-1/2				
Structural F23	D23 2.9	0.23	Flat	2-7/8	1.4	1-1/2	1-3/8	205	250	220	280
	D23 4			4	2-3/8		2-1/2	405	280	540	485
	D23 5			5	3		3-1/2				
	D23 6			6	2-3/4		4-1/2				
	D23 8			8			6-1/2				
	D23 10			10			8-1/2				
Structural F23-E	D23 3.4 XFE	0.23	Flat	3-3/8	1-1/2	1-3/4	1-5/8	-	-	220	280
	D23 5 XFE			5			3-1/4			540	485
	D23 6.8 XFE			6-3/4			3-1/2			3-1/4	
Structural F23-W	D23 2.9 XFW	0.23	Flat	2-7/8	1.4	1-1/2	1-3/8	205	250	220	280
	D23 4.4 XFW			4-3/8			2-7/8	405	280	540	485
	D23 5.9 XFW			5-7/8			4-1/2				

- Reference lateral design values apply to two-member single shear connections where both members are of the same specific gravity and the screw is oriented perpendicular to grain. When the wood members have different specific gravities, use the lower of the two.
- Values shall be adjusted by all applicable adjustment factors per NDS.
- Z Perp = lateral design value for connection with wood members loaded perpendicular to grain.
- Z Para = lateral design value for connection with wood members loaded parallel to grain.



**Structural Screws** Screw Properties and Design Values

**Table 2: Reference Withdrawal Design Values in Side Grain Applications and Head Pull-Through Design Values**

Product Name	Screw Length (in)	Thread Length (in)	Allowable Withdrawal Design Values (lbf/in) <sup>1</sup>				Allowable Maximum Withdrawal Design Values (lbf) <sup>1,2</sup>		Allowable Head Pull-Through Design Values (lbf/in) <sup>3</sup>		
			Species (SG)				Species (SG)		Species (SG)		
			HF/SPF (0.42)		DF/SP/SCL (0.50)		HF/SPF (0.42)	DF/SP/SCL (0.50)	HF/SPF (0.42)	DF/SP/SCL (0.50)	
			Thread Penetration (in)								
			1	2	1	2					
Structural H19	2-7/8	1.4	155	-	195	-	160	195	230	255	
	4	2-1/4		2-1/2		165	195				170
	6	2-1/2									
	8										
	10										
Structural H23	4	2-3/8	160	225	175	270	250	305	365	575	
	5	3					290	365			
Structural F23	2-7/8	1.4	160	-	175	-	185	215	520	490	
	4	2-3/8		2-3/4		225	270	250			305
	5	3						290			365
	6	2-3/4						275			340
	8										
	10										
Structural F23-E	3-3/8	1-1/2	160	-	175	-	195	225	520	490	
	5										
	6-3/4										
Structural F23-W	2-7/8	1.4	160	-	175	-	185	215	520	490	
	4-3/8										
	5-7/8										

1. Values shall be adjusted by all applicable adjustment factors per NDS Section 11.3 for wood screws.
2. Maximum withdrawal design values based on full thread engagement, including the tip.
3. Values based on 1-1/2" thick wood member.

lbf = pound-force  
SG = Specific Gravity

HF = Hem-Fir  
SPF = Spruce-Pine-Fir

DF = Douglas Fir  
SP = Southern Pine

SCL = Structural Composite Lumber

For the most up to date version of this Technical Guide, visit [starbornindustries.com](http://starbornindustries.com)