

# Bottom Plate to Rim Board Structural H19

Starborn® Structural H19 Truss to Top Plate / Multipurpose screws can be used to attach wall bottom plates to rim boards in accordance with IRC Section R602 or IBC Section 2308.

## Structural H19

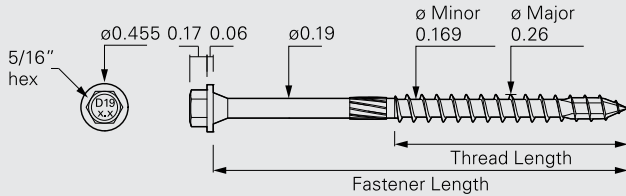

## Installation Instructions

- Select the proper length screw ensuring a minimum thread penetration of 1-3/4".
- Install using a high-torque low-speed drill with a 5/16" hex driver bit. Pre-drilling is not required, but can be used where lumber is prone to splitting.
- Drive screw downward at a 90° angle, a minimum of 1/2" from outside face of wall, through the bottom plate into the rim board (Figure 1). Drive until the washer is drawn firm and flush. Do not overdrive or countersink.

## Corrosion Resistance

- Structural H19 screws feature a high-adhesion exterior grade coating and are a code compliant alternative to hot-dip galvanized fasteners. The coating is approved for use in ACQ, Fire Retardant Treated (FRT), and other pressure treated lumbers.
- Structural H19 screws are not designed for use in or near saltwater environments.

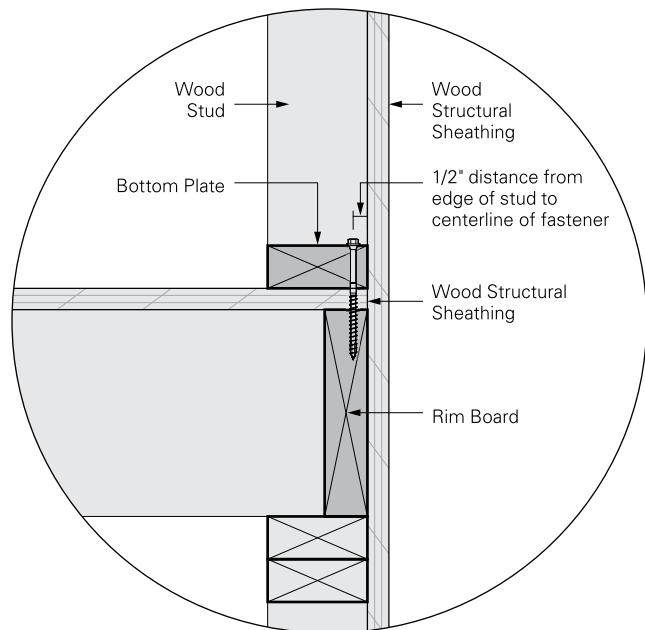

Figure 1—Single Bottom Plate to Rim Board Installation

Table 1: Screw Properties

Product Name	Head Marking	Unthreaded Shank Diameter (in)	Head Type	Screw Length (in)	Thread Length (in)
Structural H19	D19 4	0.19	Hex 5/16"	4	2-1/4
	D19 6			6	
	D19 8			8	
	D19 10			10	

1. For other specific gravities, use the allowable load corresponding to the lowest specific gravity. For Engineered Wood Product (EWP) rim boards (i.e. OSB, LSL, and LVL), the bottom plates shall be a minimum SPF dimensional lumber. Dimensional lumber minimum of 2x nominal thickness.
2. Design values include a duration load (DOL) = 1.6. No further increases permitted. Reduce design values for other load durations as applicable.

Table 2: Allowable Design Values (lbf)

Load Direction	Rim Board Species (Specific Gravity)	
	HF/SPF (0.42)	DF/SP (0.50)
Uplift	365	405
Lateral—Parallel to Grain	370	360
Lateral—Perpendicular to Grain	365	395

HF = Hem-Fir  
SPF = Spruce-Pine-Fir

DF = Douglas Fir  
SP = Southern Pine

For the most up to date version of this Technical Guide and more detailed information contained in the Truss or Rafter to Top Plate and Bottom Plate to Rim Board code compliance report (DrJ TER 1703-02), visit [starbornindustries.com](http://starbornindustries.com). For applications outside the scope of this Technical Guide, an engineered design is required.